

HCC | CHAIN CUTTERS

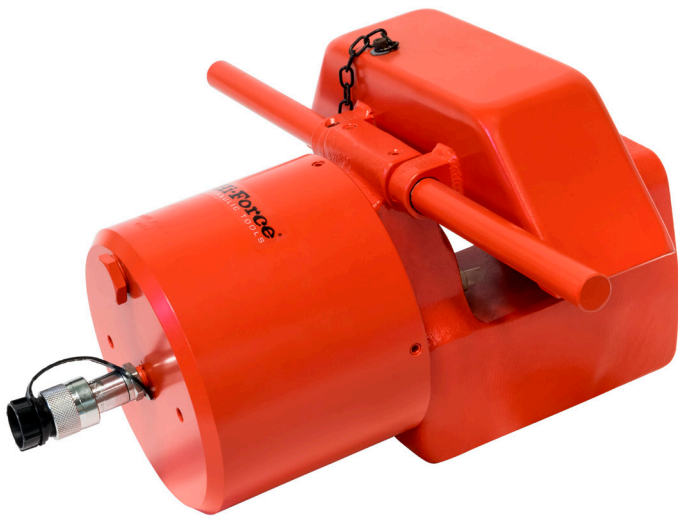

Cutting capacities up to 50 mm diameter

Smooth guillotine cutting action

Working pressure 700 bar

- ▶ Single acting spring assisted return hydraulic piston
- ▶ High grade steel construction
- ▶ Swivel locking safety guard allows easy access for material to be cut
- ▶ Specially toughened high tensile steel blades and jaws
- ▶ Includes quick connect hydraulic coupling for easy connection to pump and hose
- ▶ Designed for cutting grade 100 and 47 HRC high tensile steel chains and reinforcing bars

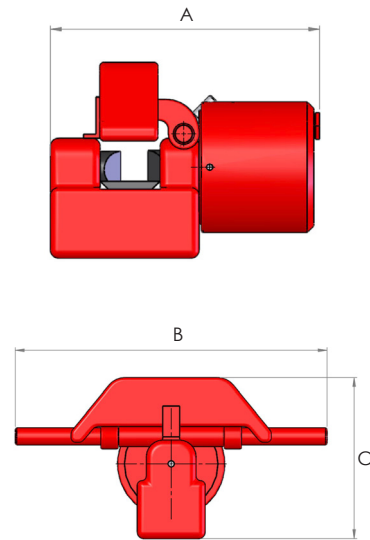

Model number	Output (tonnes)	Cutting capacity Ø (mm)	Maximum allowed		Oil capacity (cm ³)	Weight (kg)	Dimensions (mm)		
			Chain grade	Steel hardness			A	B	C
HCC26-100	70	26	100	47 HRC	276	23	440	180	180
HCC34-100	100	34	100	47 HRC	492	40	410	460	250
HCC46-100	140	46	100	47 HRC	980	72	565	635	345
HCC50-100	145	50	100	47 HRC	1100	77	565	635	360

Replacement blades for HCC chain cutter models:

Blade part number	Blade type	For cutter
HCC26-4M100	Moving	HCC26-100
HCC26-4S100	Static	HCC26-100
HCC34-5M100	Moving	HCC34-100
HCC34-5S100	Static	HCC34-100
HCC46-11M100	Moving	HCC46-100
HCC46-11S100	Static	HCC46-100
HCC50-17M100	Moving	HCC50-100
HCC50-17S100	Static	HCC50-100