



- ⇐ Jednostronnego działania, powrót sprężynowy
- ⇐ Tłoczysko węglodotowane zapewniające odporność na korozję
- ⇐ Powierzchnie łożyskowe o niskim współczynniku tarcia
- ⇐ Uszczelki zapobiegające wyciekaniu dla lepszej wydajności przy wysokich ciśnieniach
- ⇐ Gwinty kołnierza wytrzymują pełne obciążenie
- ⇐ Rowkowane siodełka montowane standardowo we wszystkich modelach

**Udźwig od 4.5 do 109 ton**

**Wysuw od 25 do 457 mm**

**Ciśnienie robocze 700 bar**

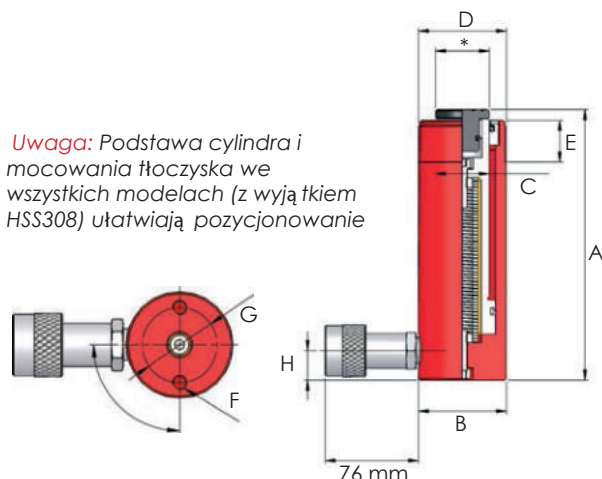

| Model    | Udźwig (t) | Wysuw (mm) | Poj. oleju (cm <sup>3</sup> ) | Pow. tłoka (cm <sup>2</sup> ) | Waga (kg) |
|----------|------------|------------|-------------------------------|-------------------------------|-----------|
| HSS51    | 4.5        | 25         | 16                            | 6.4                           | 1.0       |
| HSS52    | 4.5        | 50         | 32                            | 6.4                           | 1.2       |
| HSS53    | 4.5        | 75         | 48                            | 6.4                           | 1.4       |
| HSS54    | 4.5        | 100        | 64                            | 6.4                           | 1.5       |
| HSS55    | 4.5        | 125        | 80                            | 6.4                           | 1.8       |
| HSS57    | 4.5        | 176        | 113                           | 6.4                           | 2.0       |
| HSS59    | 4.5        | 227        | 146                           | 6.4                           | 2.4       |
| HSS101   | 10         | 25         | 36                            | 14.4                          | 1.8       |
| HSS102   | 10         | 56         | 81                            | 14.4                          | 2.4       |
| HSS104   | 10         | 100        | 144                           | 14.4                          | 3.0       |
| HSS106   | 10         | 150        | 217                           | 14.4                          | 4.2       |
| HSS108   | 10         | 206        | 297                           | 14.4                          | 5.0       |
| HSS1010  | 10         | 250        | 361                           | 14.4                          | 5.4       |
| HSS1012  | 10         | 305        | 440                           | 14.4                          | 6.2       |
| HSS152   | 14.5       | 50         | 101                           | 20.3                          | 3.4       |
| HSS154   | 14.5       | 100        | 203                           | 20.3                          | 5.0       |
| HSS156   | 14.5       | 150        | 304                           | 20.3                          | 6.6       |
| HSS1510  | 14.5       | 250        | 507                           | 20.3                          | 8.8       |
| HSS252   | 25         | 51         | 178                           | 34.9                          | 6.5       |
| HSS254   | 25         | 102        | 356                           | 34.9                          | 8.0       |
| HSS256   | 25         | 150        | 524                           | 34.9                          | 9.6       |
| HSS258   | 25         | 203        | 709                           | 34.9                          | 11.2      |
| HSS2510  | 25         | 250        | 874                           | 34.9                          | 12.6      |
| HSS2514  | 25         | 356        | 1242                          | 34.9                          | 16.8      |
| HSS2518  | 25         | 457        | 1597                          | 34.9                          | 21.4      |
| HSS308   | 29         | 205        | 860                           | 41.9                          | 18.6      |
| HSS502   | 50         | 51         | 364                           | 71.3                          | 13.0      |
| HSS504   | 50         | 102        | 728                           | 71.3                          | 16.8      |
| HSS506   | 50         | 152        | 1084                          | 71.3                          | 20.0      |
| HSS508   | 50         | 203        | 1448                          | 71.3                          | 23.2      |
| HSS5013  | 50         | 330        | 2354                          | 71.3                          | 33.6      |
| HSS756   | 73         | 152        | 1561                          | 102.7                         | 31.0      |
| HSS1004  | 109        | 102        | 1565                          | 153.4                         | 41.6      |
| HSS1006  | 109        | 153        | 2347                          | 153.4                         | 49.8      |
| HSS10010 | 109        | 254        | 3896                          | 153.4                         | 65.5      |

| Wymiary (mm) |     |     |              |    |     |     |    |  |
|--------------|-----|-----|--------------|----|-----|-----|----|--|
| A            | B   | C   | D            | E  | F   | G   | H  |  |
| 107          | 38  | 24  | 1 1/2"-16 UN | 28 | M6  | 25  | 19 |  |
| 132          | 38  | 24  | 1 1/2"-16 UN | 28 | M6  | 25  | 19 |  |
| 157          | 38  | 24  | 1 1/2"-16 UN | 28 | M6  | 25  | 19 |  |
| 182          | 38  | 24  | 1 1/2"-16 UN | 28 | M6  | 25  | 19 |  |
| 207          | 38  | 24  | 1 1/2"-16 UN | 28 | M6  | 25  | 19 |  |
| 258          | 38  | 24  | 1 1/2"-16 UN | 28 | M6  | 25  | 19 |  |
| 308          | 38  | 24  | 1 1/2"-16 UN | 28 | M6  | 25  | 19 |  |
| 100          | 57  | 35  | 2 1/4"-14 UN | 27 | M8  | 40  | 19 |  |
| 131          | 57  | 35  | 2 1/4"-14 UN | 27 | M8  | 40  | 19 |  |
| 175          | 57  | 35  | 2 1/4"-14 UN | 27 | M8  | 40  | 19 |  |
| 225          | 57  | 35  | 2 1/4"-14 UN | 27 | M8  | 40  | 19 |  |
| 281          | 57  | 35  | 2 1/4"-14 UN | 27 | M8  | 40  | 19 |  |
| 325          | 57  | 35  | 2 1/4"-14 UN | 27 | M8  | 40  | 19 |  |
| 379          | 57  | 35  | 2 1/4"-14 UN | 27 | M8  | 40  | 19 |  |
| 154          | 70  | 41  | 2 3/4"-16 UN | 39 | M10 | 48  | 19 |  |
| 204          | 70  | 41  | 2 3/4"-16 UN | 39 | M10 | 48  | 19 |  |
| 254          | 70  | 41  | 2 3/4"-16 UN | 39 | M10 | 48  | 19 |  |
| 354          | 70  | 41  | 2 3/4"-16 UN | 39 | M10 | 48  | 19 |  |
| 174          | 86  | 54  | 3 5/8"-12 UN | 49 | M12 | 60  | 25 |  |
| 225          | 86  | 54  | 3 5/8"-12 UN | 49 | M12 | 60  | 25 |  |
| 273          | 86  | 54  | 3 5/8"-12 UN | 49 | M12 | 60  | 25 |  |
| 324          | 86  | 54  | 3 5/8"-12 UN | 49 | M12 | 60  | 25 |  |
| 374          | 86  | 54  | 3 5/8"-12 UN | 49 | M12 | 60  | 25 |  |
| 480          | 86  | 54  | 3 5/8"-12 UN | 49 | M12 | 60  | 25 |  |
| 611          | 86  | 54  | 3 5/8"-12 UN | 49 | M12 | 60  | 25 |  |
| 374          | 102 | 57  | 3 5/8"-12 UN | 50 | -   | -   | 50 |  |
| 150          | 127 | 79  | 5"-12 UN     | 55 | M12 | 85  | 20 |  |
| 201          | 127 | 79  | 5"-12 UN     | 55 | M12 | 85  | 20 |  |
| 251          | 127 | 79  | 5"-12 UN     | 55 | M12 | 85  | 20 |  |
| 302          | 127 | 79  | 5"-12 UN     | 55 | M12 | 85  | 20 |  |
| 429          | 127 | 79  | 5"-12 UN     | 55 | M12 | 85  | 20 |  |
| 272          | 146 | 95  | 5 3/8"-12 UN | 45 | M12 | 115 | 32 |  |
| 223          | 185 | 114 | 6 7/8"-12 UN | 50 | M12 | 146 | 32 |  |
| 274          | 185 | 114 | 6 7/8"-12 UN | 50 | M12 | 146 | 32 |  |
| 375          | 185 | 114 | 6 7/8"-12 UN | 50 | M12 | 146 | 32 |  |