

HTWP | TORQUE WRENCH PUMPS - STANDARD LINE



Working pressure 700 bar

Two stage operation

Air or electric driven options

- ▶ Compatible for use with TWS-N and TWH-N series hydraulic torque wrenches
- ▶ Two stage operation with low pressure flow rate of up to 6.1 litres per minute
- ▶ 110, 120, 220 and 230 volt single phase electric motor with auto retract function
- ▶ Integral oil cooling system in air driven models
- ▶ Dual scale (bar/psi) glycerine filled pressure gauge
- ▶ Easily adjustable torque setting pressure relief valve
- ▶ Reservoir oil sight level gauge fitted on all models
- ▶ Air pressure gauge and filter, regulator and lubricator unit fitted on air driven models
- ▶ Oil reservoir capacity 5 litres
- ▶ Remote hand pendant controller with 3 metres cable for easy operation
- ▶ Factory fitted roll bar protection frame included

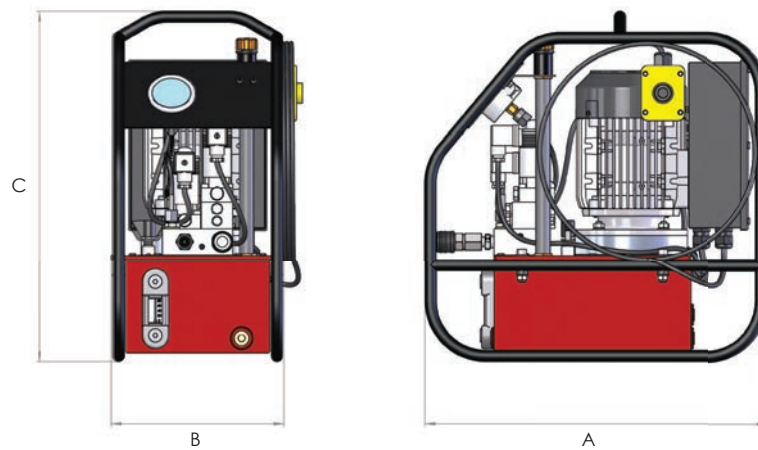

Model number	Power supply	Motor rating (kW)	Flow rate (litres/minute)		Changeover pressure (bar)	Weight (kg)	Dimensions (mm)		
			low pressure	high pressure			A	B	C
HTWP2140P	7 bar	1.5	6.1	0.51	60	28	468	205	445
HTWP2141AR	110 volt	0.75	3.7	0.34	60	34	486	245	498
HTWP2141ARH	120 volt	0.75	4.4	0.4	60	34	486	245	498
HTWP2142AR	230 volt	0.75	3.7	0.34	60	34	486	245	498
HTWP2142ARH	220 volt	0.75	4.4	0.4	60	34	486	245	498

Note: Pumps with suffix 'H' in the model number are supplied with 60 Hz electric motor.